



# MOCK EXAMINATION 1

## ENGLISH TECHNICAL

Examination Preparation

# B2







# MOCK EXAMINATION 1

## ENGLISH TECHNICAL

**Examination Preparation**

# B2

All rights reserved; no part of this publication may be reproduced, stored in a retrieval system, or transmitted in any form or by any means, electronic, mechanical, photocopying, recording, or otherwise, without the prior written permission of the publishers.

Published by telc gGmbH, Frankfurt am Main, Germany

All rights reserved

First edition 2001

Seventh edition 2021

© 2021 by telc gGmbH, Frankfurt am Main

Printed in Germany

ISBN: Booklet: 978-3-937254-30-2

Order Number: Booklet: 5109-B00-010102

MP3: 5109-MP3-010101

# To the readers of this booklet

*telc* – language tests are the right choice for you

- if you would like to have a recognised appraisal of your language proficiency, or
- if you are an instructor who would like to prepare your students for a new challenge.

## What is telc?

telc GmbH is a non-profit subsidiary of the German Adult Education Association (Deutscher Volkshochschul-Verband e.V.). It is part of a long tradition of formal and organisational promotion of multilingualism in Europe. Our specific contribution began in 1968 with the VHS Certificate in English (Volkshochschul-Zertifikat Englisch), the first standardised foreign language test in the history of the Federal Republic of Germany. Since then telc gGmbH has greatly influenced standardised language test development in Europe. Today telc offers about 80 general and work-oriented language tests in ten languages, all based on the levels of the Common European Framework of Reference for Languages (CEFR). Our examinations can be taken worldwide in more than 20 countries through our telc partners. You can find the examination centre nearest you on our website [www.telc.net](http://www.telc.net).

## What is the value of a telc Certificate?

The value of a language certificate is determined by the high standards that are applied during the development, implementation and evaluation of the language test. All telc examinations are based on the task-based approach central to the CEFR and are designed to test the skills of reading, listening, writing and speaking. These examinations are standardised and are developed according to stringent scientifically recognised methods of test development. telc gGmbH is a full member of ALTE (Association of Language Testers in Europe, [www.alte.org](http://www.alte.org)), an organisation of internationally recognised test providers. Many public and private educational institutions – in Germany and throughout the world – utilise telc Certificates as a method of qualification. Additionally, many employers use them when choosing personnel. Every telc Certificate includes a detailed and comprehensive description of the foreign language competencies achieved.

## Why is it necessary to have mock examinations?

An essential characteristic of standardised language tests is that the participants know what is expected of them during the test. The mock examination informs the test taker about the aims and tasks, and assessment criteria of the test, as well as the procedures involved in the exam implementation. telc Mock Examinations are available as free downloads at [www.telc.net](http://www.telc.net), where you can also find additional practice materials and other useful information.

## How can you find out more?

We can help you to find the test that best fits your needs. Please write to us ([info@telc.net](mailto:info@telc.net)) if you have any questions or suggestions for improvement. We would be pleased to hear from you and to have the opportunity to assist you further.



Managing Director, telc gGmbH

# CONTENTS





## Test

Test Format	5
Reading Comprehension	7
Language Elements	18
Listening Comprehension	21
Writing Faxes	29
Oral Examination	31
Answer Sheet S30	35

## Information

Marking Criteria for Written Expression	39
Marking Criteria for Oral Expression	40
How Does the Examination Work?	42
Score Sheet M10	45
Answer Key	46
Transcripts	47

# Test Format

	Subtest	Aim	Task Type	Points	Time	
Written Examination		<b>1 Reading Comprehension</b>				
	Part A	Specifications and Operations	6 multiple-choice items	6	90 minutes	
			2 true/false items	4		
	Part B	Technical Texts	15 multiple-choice items	30		
		<b>2 Language Elements</b>				
	1	Working with structures	10 multiple-choice-items	10		
	Break					20 minutes
		<b>3 Listening Comprehension</b>				
	Part A	Specifications and Operating procedures	10 fill-in items	10	approx. 60 minutes	
	Part B	Discussions and Lectures	15 true/false items	15		
Part C	Instructions and Descriptions	5 multiple-choice items	10			
Part D	Taking Notes	10 fill-in items	5			
	<b>4 Writing (Faxes and E-Mails)</b>					
	writing of 2 faxes/e-mails	Task with six guiding points	10	25 minutes		

Oral Examination	Preparation Time				20 minutes
		<b>5 Oral Examination</b>			
	Part 1	Social and General English	Talking about oneself	2½	approx. 15 minutes
	Part 2	Business & Technical Situations	Reacting to 5 situations	10	
	Part 3	Technical Description	Presentation of device or process	10	
	Pronunciation and Intonation		2½		





The first sub-tests are

## 1 Reading Comprehension

### A Specifications and Operations

### B Technical Texts

## 2 Language Elements

You are allowed a total of 75 minutes for these sub-tests. You may divide up this time as you wish between the sub-tests but it is recommended you keep to the following times for each sub-test: 15 minutes for Specifications and Operations, 45 minutes for Technical Texts and 15 minutes for Language Elements.

### 1A Specifications and Operations

This sub-test consists of two parts. The first part consists of up to two sets of product specifications with six multiple-choice items testing your ability to extract particular information from the specifications. The second part consists of up to two sets of instructions with two true/false items testing your ability to understand instructions correctly. Each item has only one correct answer.

### 1B Technical Texts

This sub-test consists of up to five technical texts with a total of 15 multiple choice items testing your understanding of the gist and the detail of the texts. Each item has only one correct answer.

## 2 Language Elements

This sub-test consists of two texts with a total of ten multiple-choice items testing your knowledge of grammatical structures and vocabulary in a technical context. Each item has only one correct answer.

## Reading Comprehension Part A – Specifications and Operations

### Pressure sensors

Below is some detailed information about four different pressure sensors.

First read items 1–3 on the opposite page. Then read the specifications below. Then choose the correct answer to each question and mark a, b or c on your answer sheet.

#### TYPE A

Measuring element	Silicon
Housing material	Titanium
Pressure range	0-60 bar max.
Accuracy	+/- 2.5% max. pressure
Maximum overpressure	4 x rated pressure
Burst pressure	> 10 x rated pressure
Supply voltage	10V at 5mA
Output	10 – 100mV
Electrical connection	1 metre integrated vertical cable
Operating temperature	-20°C to +80°C
Dimensions	diameter 21mm, length 70mm

#### TYPE B

Housing	Thermoplastic
Pressure range	5 – 15 p.s.i. (1.3 – 2 bar nominal) 0 – 30 p.s.i. (1.3 – 3 bar nominal)
Accuracy	Error less than 0.10%
Overpressure	45 p.s.i. 60 p.s.i.
Burst pressure	150 p.s.i.
Supply voltage	10V dc
Full scale output	100mV (15 p.s.i.) 79mV (30 p.s.i.)
Operating temperature	- 10°C to + 95°C
Dimensions	overall height (including connections) 20.7mm, width 16.3mm, depth 16.3mm

**Warning: Limited to fluids which do not corrode (polyester or silicon-based materials)**

#### TYPE C

Measuring principle	Precision gauge in stainless steel disc
Construction	Extremely strong stainless steel
Temperature range	200°C to + 250°C
Measured pressure	- 100 bar and 0 – 350 bar
Accuracy	better than +/- 0.12% combined nonlinearity, hysteresis and repeatability
Overpressure	twice rated maximum pressure
Burst pressure	450 bar
Excitation voltage	14V – 15V dc
Output	5V – 10V dc
Dimensions	diameter 40mm, length 91mm (including pressure connection)

#### TYPE D

Material	glass fibre/polyester
Pressure range	0 – 1.00 bar (vacuum)
Overpressure	2.75 bar
Absolute burst pressure	5.00 bar
Electrical requirements	12V dc at 0.065A
Output	0 – 100mV (zero can be adjusted 0 – 2.5V)
Wiring	4 core integral cable 0.75 long
Operating temperature	-10°C to +40°C
Dimensions	depth 40.5mm, length 40.5mm, height 25mm



- 1 You need a sensor that measures vacuum in a filter system. The power supply is 12V.  
Which sensor do you choose?
- a TYPE A
  - b TYPE B
  - c TYPE C
  - d TYPE D
- 2 You have to measure pressures of 1.5 to 1.8 bar with an accuracy of more than 0.2%.  
Which sensor do you choose?
- a TYPE A
  - b TYPE B
  - c TYPE C
  - d TYPE D
- 3 Your equipment must operate in environments with extreme temperature changes  
and high pressures. Which sensor do you choose?
- a TYPE A
  - b TYPE B
  - c TYPE C
  - d TYPE D

## Drilling Machines

Below is some detailed information about four different drilling machines.

First read items 4–6 on the opposite page. Then read the specifications below. Then choose the correct answer to each question and mark a, b or c on your answer sheet.

	Model A	Model B	Model C	Model D
Maximum drill capacity in mild steel (mm)	32	40	50	70
cast iron (mm)	40	50	60	80
Maximum drilling depth (mm)	180	210	230	260
Column diameter (mm)	125	180	200	240
Distance from column to spindle (mm)	300	385	370	390
Maximum from table to spindle (mm)	835	800	900	730
Base dimensions (mm)	600x380	535x805	545x855	600x920
Table dimension (mm)	400x420	510x510	570x570	660x775
Motor	220V/50Hz	220V/50Hz	220V/60Hz	220V/50Hz
Speeds (with motor 1450 rpm)	95/135/380 534/750/1500	61/85/123/ 269/390/ 800/1500	54/109/169/ 237/344/507/ 712/1100/1500	51/84/158/ 198/262/447/ 559/738/966/ 1260/1500
Power feed range (mm/min)	0–20	0–30	0–40	0–60
Power of main motor	1 hp	2 hp	4 hp	7.5 hp
Power of electric oil pump motor	0.12 hp	0.12 hp	0.12 hp	0.2 hp
Total height of machine	2200 mm	2380 mm	2470 mm	2570 mm
Net weight of machine	330 kg	640 kg	840 kg	1080 kg
Dimensions of transport box	930x600x 2300	1030x620x 2300	1070x670x 2480	1160x820x 2600

- 4** All the workpieces you have to drill are made of cast iron. The maximum diameter to be drilled is never more than 40mm and maximum drilling depth is 195mm. You need a drilling machine which weighs as little as possible. Which drilling machine do you choose?
- a** Model A
  - b** Model B
  - c** Model C
  - d** Model D
- 5** Power for the drilling machines is provided by electric motors. These motors rotate at
- a** 220 revolutions per minute.
  - b** 1450 revolutions per minute.
  - c** 1500 revolutions per minute.
  - d** a different speed for each drilling machine.
- 6** You want a heavy duty drilling machine which weighs less than a ton. The table should measure more than 550mm by 550mm. Which drilling machine do you choose?
- a** Model A
  - b** Model B
  - c** Model C
  - d** Model D

**Instructions**

Read each text carefully and then decide whether the statements in items 7 and 8 are true or not true and mark YES or NO on the answer sheet.

**Installing integrated “I” dishwashers –  
Fitting the (matching) door front**

The door of the kitchen base unit (without the drawer fascia or fittings) is normally used for the door front.

The door front is fixed to the machine door outer panel using a fixing bracket which has to be pre-mounted on the rear of the door front.

Templates are provided to position the fixing bracket and the door front accurately.

Fixing brackets are already fitted on the stainless steel door front. This front cannot be shortened.

Door fronts differ in weight and it is therefore essential that the door springs are adjusted after the door front has been fitted.

- 7 The door springs should be shortened or lengthened after the door has been fitted.

**Installation and Maintenance of Diesel and Natural Gas Engines**

The engine installation should be designed with maintenance requirements in mind. Serviceable components such as filters, fittings and connections should be readily accessible to the engine operator. Routine engine maintenance will be easier if the operator has good access to the engine. An overhead crane should be available in the engine room to assist the mechanic in removing heavy parts or even the complete engine, should this be necessary. Sufficient service space must be present on all sides of the engine to allow for the removal of even the largest engine components.

- 8 Standard maintenance requires the use of an overhead crane.

## Technical Texts

Read each text carefully and then choose the best answer in each set of questions and mark it on the answer sheet.

### A New Heating System

Instead of the usual gas, oil or electric heating systems, workers in a new office block in Guildford, England are being kept warm by heat taken from an underground heat store. In the summer, excess heat from the building is absorbed by the store which contains 30,000m<sup>3</sup> of rock held in a porous plastic sheet through which ground water can pass.

Heat is transferred to and from the store by a 220kW electric heat pump. According to Dr. Ian Franklin, managing director of the heat pump specialists, Geowarmth Systems, which designed the new project, the temperature of the store is not expected to drop below 6°C even in the middle of winter, allowing the temperature in the 14,700m<sup>2</sup> office to be kept at around 21°C. In the summer, when the store is used as a heat reserve, its temperature could rise to 20°C, allowing the offices in the building to be kept warm at a comfortable maximum 24°C.

In addition to space heating, the system will also provide most of the building's hot water. An electric heater will raise the water temperature by the final 10°C to 50°C.

The £600,000 project which has attracted £75,000 from the government, is expected to save the equivalent of about 70t of coal a year, giving an annual cost saving of around £10,000 over a normal heating and air-conditioning system.

9 Workers in an office block in Guildford are being kept warm in winter by

- a "geothermal heat" (heat drawn from the earth's heat).
- b heat drawn from ground water by a heat pump.
- c "summer heat" trapped in a heat store.

10 In summer, the temperature in the office blocks does not rise above

- a 21°C.
- b 24°C.
- c 20°C.

11 The new heating system

- a will heat water to 60°C.
- b will save £10,000.
- c will use 70 tons of coal a year.

## Superplastic Aluminium Alloys

Superplastic aluminium alloys (SPA) – those which behave like plastic when heated and metal when cold – have been commercially exploited in the aerospace industry since the early 1970s. Yet it is only during the last ten years or so that they have begun to be used in the manufacturing industry in general. This has led to new applications in fields as diverse as electronics, medical equipment, architectural components, the auto industry and public transport (especially railways).

Technically, a superplastic aluminium alloy is one which exhibits high tensile ductility at low strain rates, coupled with a high elongation and low flow stress at higher temperatures. Of these characteristics, the most important one is the elongation factor. In most applications, this will be slightly less than 200%, in order to maintain an acceptable material thickness, although it is technically possible to achieve a factor of more than 1000%. It is of course this stretching capability which facilitates the compressed air forming of complex shapes from a single sheet, a capability which holds many attractions for industrial designers.

LITAL 8090-SPA, for example, is an aluminium lithium alloy specially developed for aerospace applications which offers a reduced weight (of up to 10% less than conventional aluminium alloys), together with a similar degree of increased rigidity or stiffness. For increased room temperature ductility and corrosion resistance there are alloys such as LITAL 5083-SPA.

The use of compressed air forming techniques has the further advantage of high finish quality since only one component surface comes into contact with the tool. This allows low tooling costs – the majority of the tools are machined from aluminium alloys or ferrous metals. There are now three individual forming methods in common use, the chosen technique depending on size, the kind of aluminium alloy used and the complexity of the design itself. These three methods are male forming, female forming and drape forming.

Whichever method is used, however, it is the exceptional design freedom offered by the combination of air pressure forming with a metal capable of behaving like plastic, which is the most important advantage to the manufacturing industry. It is this special combination which makes the SPA process so suited to the production of components with complex shapes. But it is only recently that other valuable manufacturing advantages have begun to be widely appreciated. An important advantage is the ability to produce complicated parts from a single sheet, minimising the need for additional manufacturing and assembly. Using SPA aluminium alloys reduces production times and costs and this frequently enables designs to be simplified and component weights to be reduced. Some components that were previously made from ten individual sheet metal details can now be produced in one single forming process.

Strength is not the only advantage offered by the alloys. Although some plastics now possess better strength to weight ratios than SPA alloys, SPA is still specified by most aerospace designers because of its better fire resistance.

Because of all the advantages of superplastic aluminium there seems little doubt that it will continue to be used more and more, at least for small to medium production volumes where some kind of sheet metal or plastic would be the standard alternative. The combination of increased design freedom, high finish quality, good mechanical properties and low tooling costs offer manufacturing possibilities not found in other materials. Also aluminium is recyclable. This is an added advantage in a world in which the environmental impact of manufacturing is becoming increasingly more important.



**12** Superplastic aluminium alloys

- a** are new materials made of plastic and metal.
- b** have been used for some time in general production.
- c** are no longer used in the aerospace industry.

**13** Superplastic aluminium alloys

- a** are produced using the compressed air technique.
- b** are very brittle at low strain rates.
- c** can be stretched to more than ten times their original length.

**14** A component made of LITAL 8090-SPA

- a** is lighter than one made from a conventional aluminium alloy.
- b** has better corrosion resistance than one made from LITAL 5083-SPA.
- c** is less rigid than one made from other aluminium alloys.

**15** The use of compressed air methods means that

- a** both sides of the component are touched.
- b** inexpensive forming tools can be used.
- c** the same method can be used for all sizes of component.

**16** The SPA process

- a** is only applied to the forming of complex shapes.
- b** allows complicated shapes to be produced from one sheet.
- c** offers little advantage in the assembling process.

**17** SPA components

- a** are more expensive to produce than conventional aluminium components.
- b** can be shaped from a single sheet in up to ten individual forming steps.
- c** weigh less than standard aluminium components possessing the same strength.

**18** Components made of SPA

- a** are easily recyclable.
- b** are stronger and lighter than plastic components.
- c** can be easily produced on a large scale.

## Text Message Via Email – Any Way you Like it

Need to receive a social media text message but don't have or want a social media account? XOIP (pronounced keysop), a three-year-old Dutch firm, offers Internet users a free service by which they can receive social media messages through their email accounts. The company gives clients a special account number to be used as a personal account number. XOIP forwards any text messages received on that number to the user's email address as an image file. The sender of the text message receives a delivery message once the client reads the text. No special software is needed. More than 100,000 people already use the service, which also includes a free voice mail system that transmits voice messages as downloadable sound files to the client's computer.

- 19 This new service is for those who
- a already have a social media account.
  - b don't have an email address.
  - c want to get text messages without a social media account.
- 20 In order to receive text messages, users of the system
- a are given a new number to use for text messages.
  - b get a new email address for a social media account.
  - c use their own telephone number for a social media account.
- 21 The service
- a needs a special social media software.
  - b does not require any special browser software.
  - c is only available in the Netherlands.

## Lamp Holders

IVOTECHS lampholder isolates the light bulb contact as soon as a bulb is removed, preventing the chance of electrical shock from the exposed contacts. The result of a suggestion from a private inventor and bought by IVOTECHS, the lampholder is designed for standard bulb fittings and was the first major improvement for over 100 years, say IVOTECHS.

One of the main obstacles to be overcome in the development of the lampholder was the selection of a suitable material. This needed to be stable at high temperatures to ensure that the mechanism would not stick. The final choice, PET, was tested at temperatures of up to 230°C for two years with no sign of deterioration. This is 80°C more than can be expected under normal conditions.

The lamp holder allowed IVOTECHS to enter the market for electrical fittings. Despite its extra features, however, it has always sold at a price which is competitive with other products.

**22** The lamp holder

- a** can be used with ordinary light bulbs.
- b** was invented by IVOTECHS.
- c** was originally invented 100 years ago.

**23** The material used for the lamp holder, PET,

- a** deteriorates at temperatures under 80°C.
- b** is guaranteed for two years.
- c** remains intact at high temperatures.

## Language Elements

Read the following texts and decide which word or phrase a, b, c or d is missing in items 24–33. Mark your answers on the answer sheet.

### The Battery and the Charging Circuit

In a car, electrical energy (produced by chemical action) is 24 in the form of current flow to electrical components when they are connected to the battery. As the battery continues to supply current, all the available chemical energy stored is used up. In order to 25 additional current, the chemical energy must be restored to the battery. The generator does this 26 current to the battery in the opposite direction to the discharge. 27 the battery is a chemical device, it should be noted that the generator is electro-mechanical, converting mechanical power from the engine into electrical power. When the battery is being charged by the generator, the voltage 28 across the battery is called the “charging voltage”.

- 24** a prepared  
b presented  
c processed  
d provided
- 25** a reach  
b require  
c prevent  
d supply
- 26** a by sending  
b in order to send  
c in sending  
d sending
- 27** a As  
b Because  
c When  
d Whereas
- 28** a measured  
b measures  
c measuring  
d be measured

## High Technology in Building

One measure of the efficiency of a building particularly liked 29 structural engineers is the way a load goes from the top to the ground. In the Bank of China building in Hong Kong 30 has 70 floors, the load takes the usual way downward. But the building is not of usual height and this area has very strong winds. Instead of two structural systems, one for the vertical loads and the other for the purpose 31 wind forces, the building only has a single system for both of these. Lightweight steel bars form a three-dimensional frame which 32 the vertical planes of the four faces of the building and the two diagonals. The frame transfers the loads to the vertical columns of reinforced concrete which 33 the loads directly to the ground.

- 29** a by  
b from  
c to  
d with
- 30** a what  
b which  
c who  
d whose
- 31** a by resisting  
b of resisting  
c resist  
d to resist
- 32** a adds  
b attaches  
c breaks  
d connects
- 33** a are taking  
b take  
c have taken  
d took



**Listening Comprehension**

### 3 Listening Comprehension

- A Specifications and Operating Procedures**
- B Discussions and Lectures**
- C Instructions and Descriptions**
- D Taking Notes**

The time for these sub-tests is approximately 85 minutes, depending on the length of the recording.

For this sub-test you need the MP3 (Order No. 5109-MP3-010101).

All the pauses are on the recording. In the real examination the recording will not be stopped.

#### **A Specifications and Operating Procedures**

This sub-test consists of a recording describing one or more diagrams with ten items to be completed, either by filling in a missing word or phrase or by deciding whether a statement is correct or incorrect according to what you hear on the tape. You should write the missing words or phrases or mark YES or NO on your answer sheet.

#### **B Discussions and Lectures**

This sub-test consists of a recording of a discussion, interview or lecture with 15 statements testing your understanding of the gist and the detail. You should decide whether the written statements are correct or incorrect according to what you hear on the tape. You should mark YES or NO on your answer sheet.

#### **C Instructions and Descriptions**

This sub-test consists of five short recordings of technical instructions or descriptions with one multiple choice item for each recording testing your understanding of what is being said. Each item has only one correct answer.

#### **D Taking Notes**

This sub-test consists of ten short recordings each containing one piece of information in answer to a question which you can read in your examination booklet. You should write the answer on the answer sheet.

In all these sub-tests you may make notes but in the real examination marks can be given only for the answers which are written on the answer sheets. Notes will be destroyed by the examination centre. Make sure you have enough time to write your answers on the answer sheets.

## Part A, SPECIFICATIONS AND OPERATING PROCEDURES

### Two Valves Used to Control Pressure

The two diagrams, I and II, illustrate the two different types of valves used to control the flow of water. Some parts have been labelled A–K.

First look at the general layout of the diagrams and read the test items.

Then listen to the speaker.

You will hear the text in two parts.

You may take notes if you wish.

After each part, you will have time to study the diagrams again and read the test items. Decide whether the sentences are correct **-YES-** or incorrect **-NO-** and add the missing words.

You will then hear the complete text a second time.

When you have heard the complete text a second time, check your answers and transfer your answers to the answer sheet.

Please note: Minor spelling mistakes will not affect the result.

Before the speaker starts you have 90 seconds to study the diagrams.

- 34** Part A is referred to as \_\_\_\_\_ .
- 35** Part D is referred to as the pressure chamber.
- 36** Part B is mentioned.
- 37** Part C is made of \_\_\_\_\_ .
- 38** This type of valve can be easily adjusted.
- 39** The more the water level in the tank rises, the more the float falls.
- 40** Parts F are referred to as \_\_\_\_\_ .
- 41** Part G is mentioned.
- 42** Parts H are referred to as \_\_\_\_\_ .
- 43** Part K has a safety function.



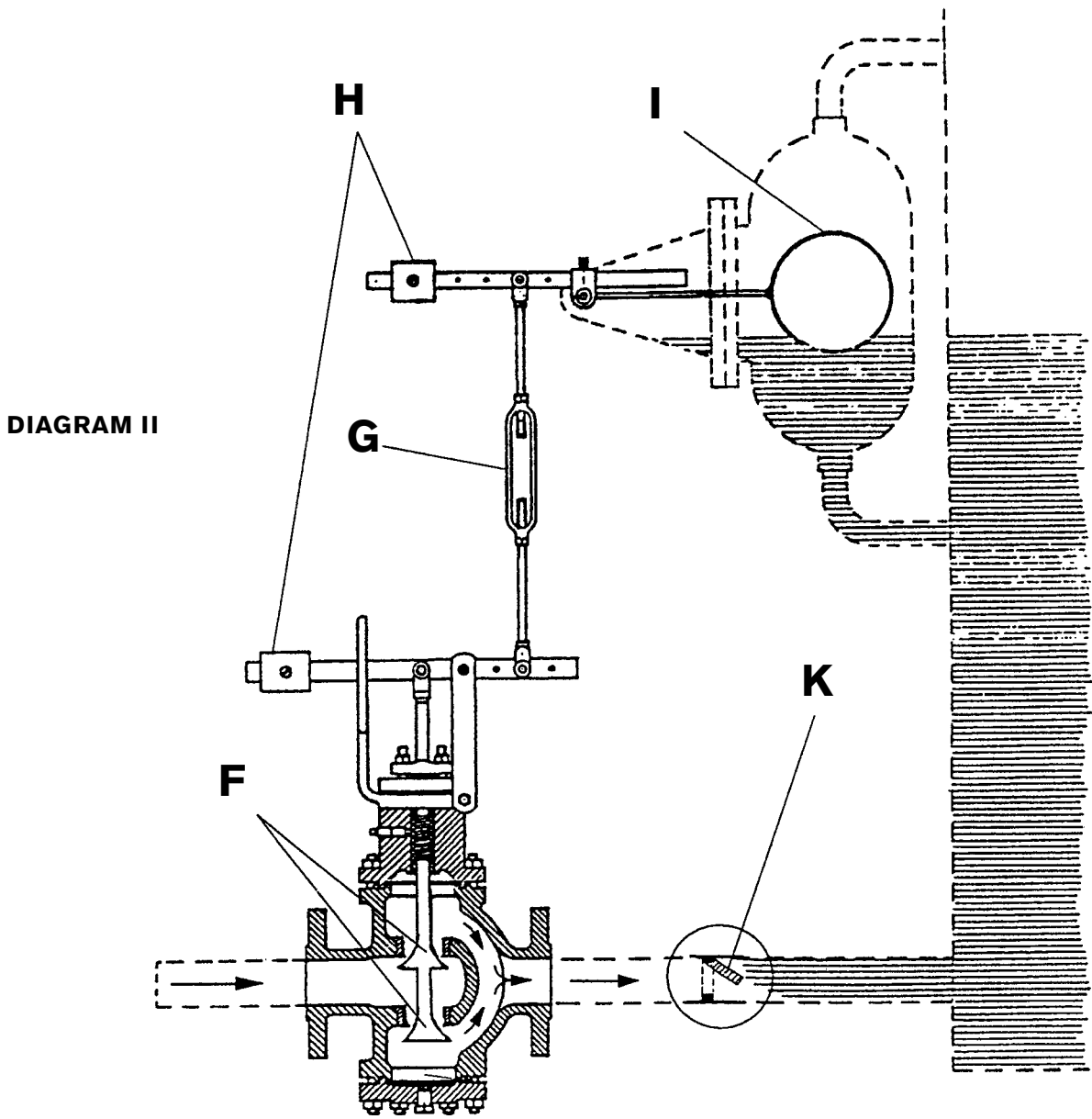
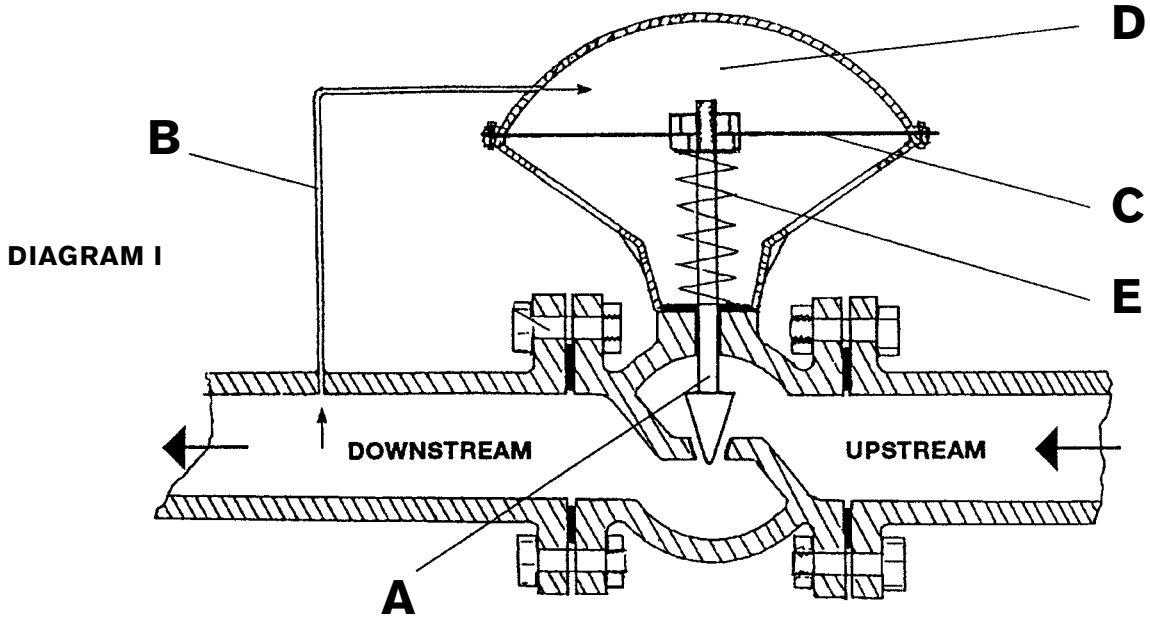

## Part B, DISCUSSIONS AND LECTURES

### Danger – Risky Kinobis

*You will now hear an interview from a radio programme .*

*Recent tests have shown that some cars are dangerous to drive. You are going to hear an interview with a representative of the Car-Owners' Association, talking about tests done and the results found. She will be talking about one type of car in particular – the Kinobi BK.*

*First read the test items 44–53 on the examination paper. You will have two minutes for this.*

*Then listen to the interview.*

*After that you will hear the interview again, this time in two sections.*

*After each section you will have time to mark whether the sentences are true - YES - or not true - NO - on your answer sheet.*

*You now have two minutes to read the test items.*

- 44** American and British car-owners' associations co-operated closely in testing Kinobi BKs.
- 45** Kinobi BKs slide too easily when going around corners.
- 46** The British test driver could not complete the test.
- 47** The same test has been done on many other cars.
- 48** Careful driving can prevent the car rolling over.
  
- 49** Two people have already been killed due to Kinobi BKs rolling over.
- 50** In the US 95 people have been hurt in Kinobis which have rolled over.
- 51** Kinobi has warned all owners of this danger.
- 52** Accidents have also happened in Kinobis when making a sudden stop.
- 53** The Car-Owners' Association will send details to interested drivers.

## Cooling Down process heat

You will now hear a speaker describing ways of cooling down process heat in power stations. First look at the diagram and read the sentences 54–58.

You will have 90 seconds for this.

Then listen to the speaker.

After that you will hear the speaker again.

Then mark whether the sentences are true - YES - or not true - NO - on the answer sheet.

You now have 90 seconds to study the diagrams.

- 54** All thermal power stations produce waste heat.
- 55** The once-through cooling system shown in Figure A is equipped with a heat exchanger.
- 56** Pump Y in Figure B pumps only small amounts of water to the cooling tower.
- 57** Figure B shows a cooling system in which the rising air can be used to drive fans to produce electricity.
- 58** Natural draft design cooling towers are sometimes more problematic for the environment than electrically powered fan driven ones.

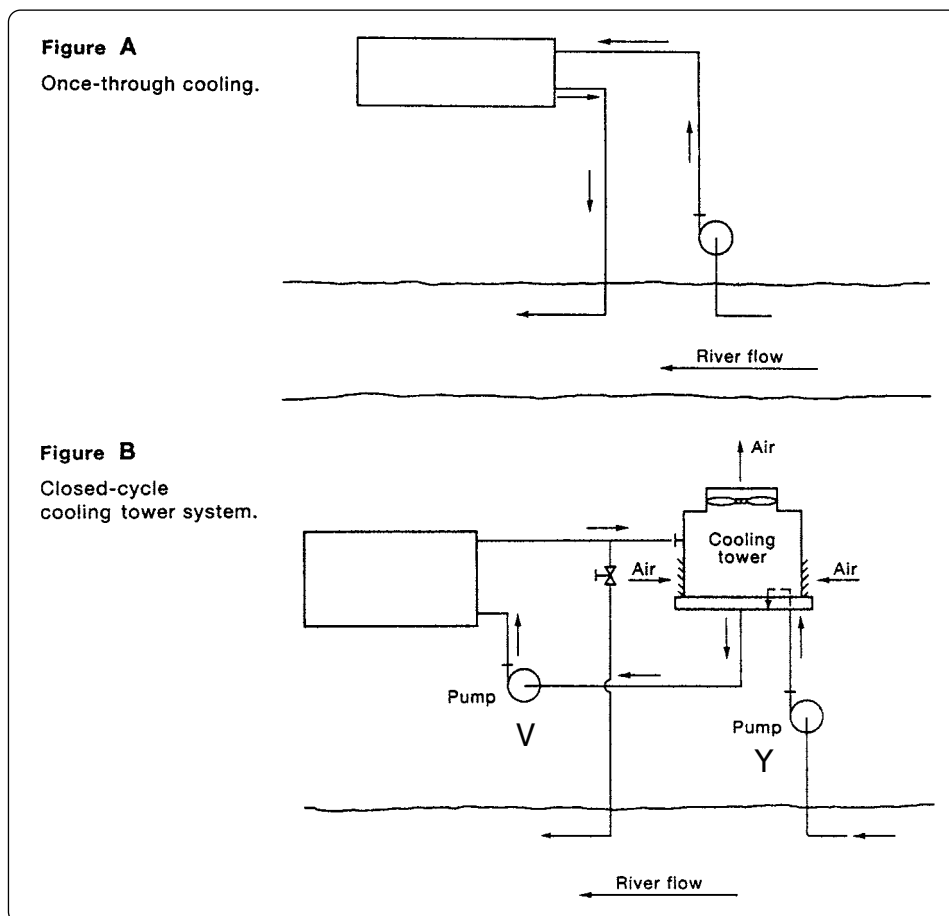

## Part C, INSTRUCTIONS AND DESCRIPTIONS

You will now hear five short texts. Before you listen to each individual text first read the test items and look at the diagrams (if provided). You will have 60 seconds for this.

Then listen to the text.

Then read the sentences again.

Now listen again and decide which test item is correct according to the information given.

Mark your answer - a, b, or c - on the answer sheet.

You now have 60 seconds to read the test items.

### 59 New Developments in the Car Industry

The new ABB development

- a can be quickly recharged at special charging stations.
- b does not produce gaseous emissions.
- c weighs four times more than normal batteries.

### 60 Shop-Floor Safety Instruction

When you work at a lathe

- a clean the machine with compressed air after you have finished your work.
- b don't work in oily clothes.
- c keep the cutting fluid in a metal container.

### 61 Solar Heating

Diagram A shows

- a a one-axis concentrator.
- b a system that requires two pumps.
- c a system that works constantly.

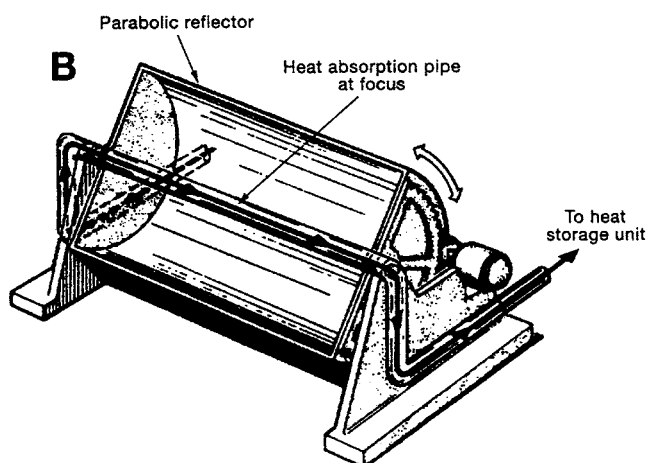
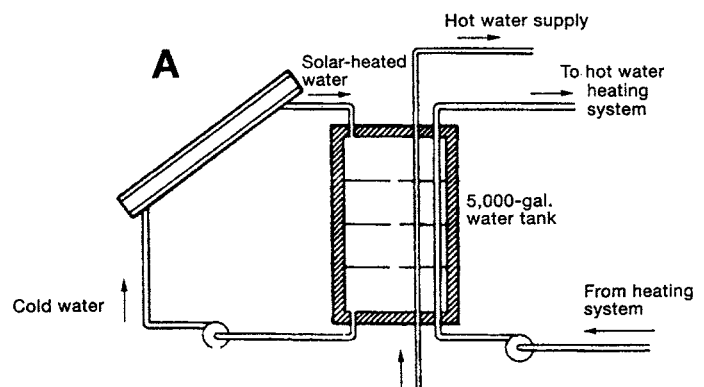

## 62 High Tension Cables for Car Ignition Systems

In the new high tension cables

- a a lower resistance copper core is used.
- b insulating material is no longer necessary.
- c resistance against environmental effects has been increased.

## 63 Comparing Energy Costs

Column A represents the end price for

- a electric power.
- b hydrogen energy.
- c natural gas.

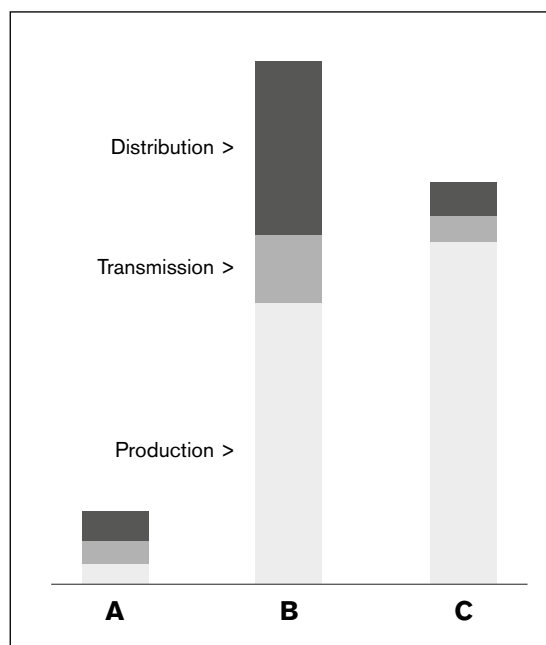

**Part D, Taking Notes**

In this section you will hear ten short recordings. Listen to each recording and then make a note of the information given on the answer sheet as in the example below.

Please note: You will hear the recording only once.

Please note: You will hear the recording only once.

**Example:**

Question: "What is the power range of your motors?"

"We can supply motors from 1.25 to 9.8 horsepower"

Answer:

**1.25 hp – 9.8 hp** or

**1.25 to 9.8 horsepower** or

**1.25 to 9.8**

- 64 What is your name, please?
- 65 How many employees do you have exactly?
- 66 When can you deliver the goods?
- 67 What size is the paper?
- 68 What is the initial cost of each lens?
- 69 Can you give me your fax number?
- 70 What size are they?
- 71 What is the weight of the consignment?
- 72 How much is the VAT on that order?
- 73 Can you tell me the invoice number?



## Writing Faxes

*The time for this sub-test is 25 minutes.*

*In this sub-test you have to write two faxes, each based on three guiding points. You are given a context consisting of a situation or a fax which you or your company have received and to which you write in reply. You may make notes or write a draft but in the real examination marks can be given only for faxes which are written on the answer sheets. Notes will be destroyed by the examination centre. Make sure you have enough time to write your faxes on the answer sheets*

*This is the last sub-test in the written examination.*

**Fax 1**

*You work for a company which produces and sells video equipment for conferences. You have received the following enquiry.*

Dear Sir/Madam

Please send me some information about the equipment your company produces. Our company is considering the possibility of installing equipment for video conferencing.

I would be grateful if you could send me details of your equipment, including prices and delivery conditions. Would it be possible for you to send someone to demonstrate how the equipment works?

I look forward to hearing from you soon.

Yours faithfully,

Marion Hopkins  
Purchasing Manager

*Write a fax in reply. Include the following points.*

- 74** Thanks for inquiry
- 75** Sending brochure
- 76** Representative will contact her

**Fax 2**

*You ordered a set of industrial drills from a company several weeks ago. You have heard nothing from them since and now need the drills urgently. Write a fax to the company. Include the following points:*

- 77** Refer to order
- 78** Stress need for drills
- 79** Say what you will do if drills not sent soon



## Oral Examination

Each oral examination takes place with one candidate and two examiners. One of the examiners will do most of the talking.

The oral examination consists of the following sub-tests

- 1 Social and General English**
- 2 Business and Technical Situations**
- 3 Technical Description**

The oral examination takes about 15 to 20 minutes.

### 1 Social and General English

In this sub-test you talk to the examiners about yourself. You are expected to talk freely and include information about work, study, home and interests. The examiners may ask you questions. You will be marked on how freely you speak and the language you use.

### 2 Business and Technical Situations

In this sub-test you respond to 5 business and social situations which the examiner will read to you. You are not allowed to take notes. You may ask the examiner to repeat each situation once.

### 3 Technical Description

In this sub-test you talk about an object, diagram or process from your working environment. You should be prepared for this and bring the material you need (object, drawings etc) with you. You may make notes and bring these with you but should not read from these during the examination. The examiners can ask you questions about the material.

## Examination Schedule

	Material	Time in minutes
Preparation (if necessary)	Candidates' Task Sheets	20
<b>Part 1</b> Social and General English	Examination booklet	3-5
<b>Part 2</b> Business and Social Situations	Examination booklet	5
<b>Part 3</b> Technical Description	Examination booklet	5-7
Examiners' Discussion	Score Sheets Answer Sheets	4-5

## Oral Examination

**80** The following section is marked!

The candidate is expected to talk freely for three to five minutes. The examiners may prompt with questions such as:

*Where do you live?*

*Do you work full-time?*

*Do you use English often?*

*What are your interests or hobbies?*

*What sort of training have you had?*

*Do you travel a lot?*

*What are your working/study hours?*

Now we would like to ask you what you would say in certain business and social situations. If there is something you don't understand we can repeat the question once.

### Version 1

- 81** You are going to show a group of foreign technicians around your company. Introduce yourself and say something about the tour.
- 82** A representative from a company manufacturing photocopiers asks if your company would be interested in installing new photocopiers. Say you are not interested and explain why.
- 83** At an engineering exhibition you want more information about a particular product. Ask for this information and say why you are interested in the product.
- 84** A visitor comes to your office and asks to speak to your boss. Your boss is away on a business trip at the moment. Explain the situation and offer to help.
- 85** You are taking some visitors on a tour of your company. One of them asks if he may smoke. Tell him this is not possible and explain why.

### Version 2

- 81** You are not very happy with the photocopying machines used in your company. Tell the supplier this and explain why.
- 82** Your assistant has not completed a piece of work on time. Say you are not very happy about this and tell him what you want him to do.
- 83** You are on a business trip to an English company. You are offered a cup of tea. Refuse and say why you don't want one.
- 84** You want to invite a foreign visitor to your company out to dinner. Tell him this and ask him what sort of food he prefers.
- 85** You are visiting a company for the first time. Introduce yourself at the reception desk and ask for directions to the Sales Department.

## Oral Examination

In this part of the examination the candidate will present a component, diagram or drawing s/he has brought to the examination. The following questions are suggestions for the examiners. The actual questions will depend on the candidate's presentation.

*Can you describe the parts (of the diagram) individually ?*

*Can you explain (in more detail) how the system works?*

*What (else) could this be used for?*

*Can you suggest any improvements or modifications?*

*Is this the latest design or are there any further developments?*

*How long has this design been in use?*

*What (other) materials are used for the manufacture of this product?*

*What advantages does this product have over others?*

*Do you think this design will last a long time or can you foresee possible changes?*

If the candidate has not brought any material to the examination, the diagram and text provided here can be used. In this case the candidate is given 15 minutes to prepare for the sub-test Technical Description. Candidates should be encouraged to bring their own material to the examination as in general they will score better in this part of the oral examination if they are talking about an object or process which is familiar to them. The following questions may be asked by the examiners:

*What is the installation used for?*

*Could you describe the air flow through the individual components?*

*What is the purpose of the heat exchanger?*

*What is the purpose of the compressor?*

*What is the starter used for?*

*Why are starter, generator, compressor and turbine all mounted on the same shaft?*

*How is the fuel ignited?*

*Can you suggest modifications?*

*How fast do you think the turbine and compressor rotate?*

**M50-Eng(B2)T/Mock1** (For the participant)

**Oral Examination**

Please return to the examiner after use!

**Gas Turbines**

Gas turbines are driven by the combustion gases from liquid fuels. They resemble steam turbines in that a flowing medium – i.e. the combustion gases – produces a rotary motion as a result of driving a rotor. The operation of a gas turbine is shown schematically in Fig. 1: the compressor draws in fresh air and compresses it to a pressure of 50 – 70lb/in.<sup>2</sup>; the compressed air passes through a heat exchanger where it is preheated by the very hot exhaust gases; now the preheated air is admitted into the combustion chamber. In this chamber liquid fuel is burned, thereby producing gases with a temperature of about 650 degrees Celsius. These combustion gases flow at high velocity into the turbine and drive it.

The turbine itself, the compressor, and the electric generator are all mounted on one shaft. The turbine cannot transmit its entire power to the generator because a substantial part is needed for driving the compressor. The turbine is started with an electric motor which first has to set the compressor in motion in order to produce the compressed air necessary to form the combustion gases. Fig. 2 shows the main features of the gas turbine.

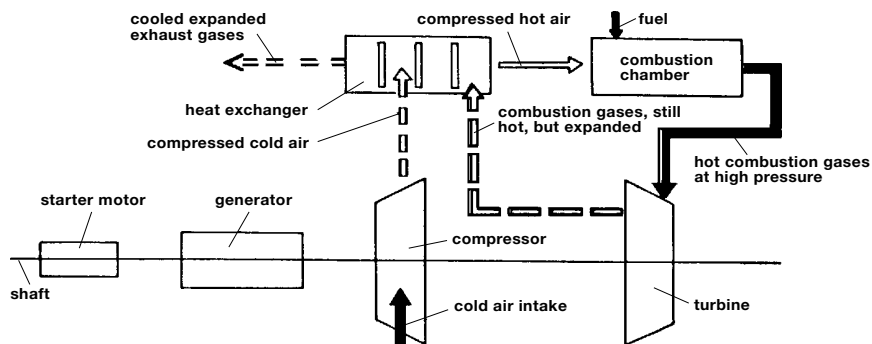

Fig. 1 GAS TURBINE (schematic)

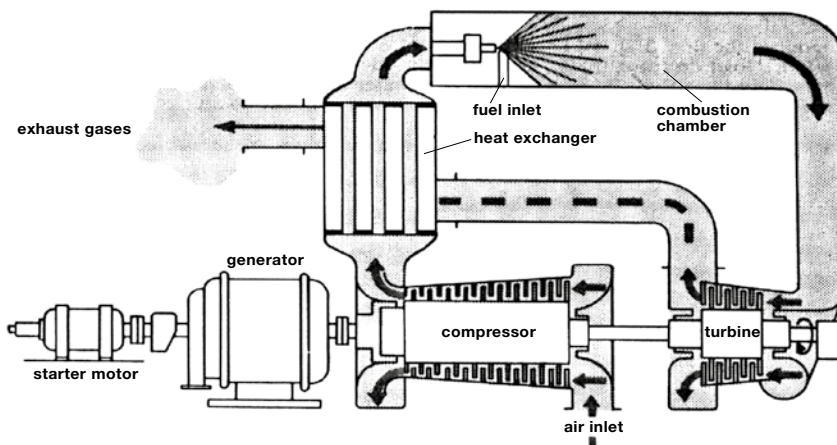



Fig. 2 GAS TURBINE

No part of this examination may be copied or stored under any circumstances. All violations will be prosecuted !  
Dieses Dokument darf unter keinen Umständen kopiert oder aufbewahrt werden. Jeder Verstoß wird gerichtlich verfolgt !

										1	1	0	9				
--	--	--	--	--	--	--	--	--	--	---	---	---	---	--	--	--	--

# ENGLISH B2 TECHNICAL



<input type="text"/> Familienname · Surname · Apellido · Nom · Cognome · Apelido · Příjmení · Фамилия																				
<input type="text"/> Vorname · First Name · Nombre · Prénom · Nome · Nome próprio · Jméno · Имя																				
<input type="text"/>			<input type="text"/>			<input type="text"/>			<b>Beispiel: 23. April 1989</b> <b>Example: 23<sup>rd</sup> April 1989</b>			<input type="text"/>			<input type="text"/>			<input type="text"/>		
Geburtsdatum · Date of Birth · Fecha de nacimiento · Date de naissance · Data di nascita · Data de nascimento · Datum narození · День рождения																				
<input type="text"/> Geburtsort · Place of Birth · Lugar de nacimiento · Lieu de naissance · Luogo di nascita · Local de nascimento · Místo narození · Место рождения																				
<input type="text"/>																				
Muttersprache · First Language · Lengua materna · Langue maternelle · Madrelingua · Língua materna · Mateřský jazyk · Родной язык																				
<input type="checkbox"/> männlich · male · masculino · masculin · maschile · masculino · muž · мужской <input type="checkbox"/> weiblich · female · femenino · féminin · femminile · feminino · žena · женский																				
Geschlecht · Sex · Sexo · Sexe · Sesso · Sexo · Pohlaví · Пол																				
<input type="text"/> Prüfungszentrum · Examination Centre · Centro examinador · Centre d'examen · Centro d'esame · Centro de examinação · Zkušební centrum · Экзаменационное учреждение																				
<input type="text"/>			<input type="text"/>			<b>Beispiel: 17. Februar 2008</b> <b>Example: 17<sup>th</sup> February 2008</b>			<input type="text"/>			<input type="text"/>			<input type="text"/>					
Prüfungsdatum · Date of Examination · Fecha del examen · Date d'examen · Data dell'esame · Dia do exame · Datum zkoušky · Дата экзамена																				
<input type="text"/> Testversion · Test Version · Versión del examen · Version d'examen · Versione d'esame · Versão do exame · Číslo verze testu · Тестовая версия																				

- 001 – Deutsch
- 002 – English
- 003 – Français
- 004 – Español
- 005 – Italiano
- 006 – Português
- 007 – Magyar
- 008 – Polski
- 009 – Русский язык
- 010 – Český jazyk
- 011 – Türkçe
- 000 – andere/other









# Marking Criteria for Written Expression

A total of 10 points, 5 for each fax, can be awarded according to the following marking criteria:

For each guiding point which is covered in fully comprehensible English and is appropriate to the task set, one point will be awarded, making a total of three possible points. Language errors will only be taken into consideration if they lead to a breakdown in communication. If the examiner believes that the central element in an item may not be understood by the recipient, 0 points will be awarded for that item.

Up to two points can be awarded for each fax for the general impression given by the handling of the fax as a whole. 2, 1 or 0 points can be awarded for this.

## Guiding Points 74 -79

All parts of the guiding points must be dealt with in order to gain 1 point. Only the information required in the guiding points should be marked. Any other information in the faxes is to be considered when awarding points for general impression.

**0 points** = meaningless, incomprehensible or irrelevant response; wrong information; no response at all.

**1 point** = correct and appropriate, covering all parts of the guiding point.  
Language errors should not be taken into account here.

## General Impression

0, 1 or 2 points can be awarded for general impression for each fax taken individually.

**0 points** = The entire fax is incomprehensible and/or  
0 points have been awarded for the guiding points.  
The fax does not correspond to the task set.

**1 point** = Fair linking and only occasionally inappropriate style. Some language errors but none impairing comprehension or communication.

(If the language errors are so numerous and severe that comprehension is impaired, then 0 points should be given.)

**2 points** = Good linking and largely appropriate style. Few language errors but none of these impairing comprehension and communication.

# Marking Criteria for Oral Expression

The marking of the oral examination is carried out individually during the examination by each of the two examiners. After the candidates have left the room, the examiners reach a consensus on the marks to be awarded for each candidate.

The candidates' performance is assessed according to the following four criteria:

- Criterion 1: Social and General English
- Criterion 2: Task Business and Technical Situations
- Criterion 3: Technical Description
- Criterion 4: Pronunciation and Intonation

## Criterion 1: Social and General English

		Points
<b>A</b>	The candidate speaks freely about him/herself and his/her work. The language is largely free of mistakes. Examiner prompts are kept to a minimum and are not necessary to keep the conversation going but rather to elicit further information on particular matters.	5
<b>B</b>	The candidate speaks freely about him/herself and his/her work. The language contains several mistakes but these do not impair communication. Examiner prompts are kept to a minimum and are not necessary to keep the conversation going but rather to elicit further information on particular matters.	3
<b>C</b>	The candidate speaks freely about him/herself and his/her work but the language contains several mistakes making checking questions necessary, <b>or</b> the candidate is not in a position to speak freely and examiner prompts are necessary to keep the conversation going.	1
<b>D</b>	The candidate is not able to participate in this sub-test, i.e. does not speak at all, <b>or</b> what the candidate says has no relevance to him/herself or his/her work, <b>or</b> what the candidate says is incomprehensible.	0

## Criterion 2: Business and Technical Situations

		Points
<b>A</b>	The response corresponds to the task set. It includes enough detail and is largely free of mistakes.	4
<b>B</b>	The response corresponds to the task set. It includes enough detail but contains a number of mistakes, <b>or</b> within the context of natural communication it is very short, but contains no mistakes.	3
<b>C</b>	The response corresponds to the task set, but it is too short within the context of natural communication and contains a number of mistakes, <b>or</b> the response is not entirely clear or appropriate in relation to the task set so that in a real-life situation a checking question would be necessary. This mark is also awarded if only one part of the situation is given as a response.	1
<b>D</b>	The response does not correspond to the task set, <b>and/or</b> the response is incomprehensible.	0

**Criterion 3: Technical Description**

		Points
<b>A</b>	The performance is clear and fluent with very little hesitation requiring hardly any prompts by the examiner. The language is largely free of mistakes.	20
<b>B</b>	The performance is clear and fluent with little hesitation but contains a number of mistakes. <b>or</b> the performance is largely free of mistakes but the description is in itself not sufficiently clear and/or fluent so that the examiner has to use a number of prompts.	16
<b>C</b>	The description is unclear and lacks fluency and also contains a number of language mistakes, so that the examiner has to make frequent use of prompts and checking questions.	8
<b>D</b>	Despite the use of prompts and checking questions by the examiner the description is unclear and inappropriate.	0

**Criterion 4: Pronunciation and Intonation**

		Points
<b>A</b>	Pronunciation and intonation show little divergence from accepted norms.	5
<b>B</b>	Pronunciation and intonation differ from accepted norms, but this does not impede understanding.	3
<b>C</b>	Pronunciation and intonation differ considerably from accepted norms, causing difficulty in understanding.	2
<b>D</b>	Pronunciation and intonation differ so greatly from accepted norms that comprehension is very difficult or impossible.	0

The total result is divided by 2. A candidate who is awarded 50 points will obtain a final result of 25 points to be added to the overall result of the complete examination.

# How Does the Examination Work ?

## Scoring using the Answer Sheet S30

The Answer Sheet S30 is a thin booklet with three perforated pages. All of the testing results are recorded on these sheets. The candidates record their answers for the “Reading” and “Listening” subtests on pages two and three. The examiners mark their results for the oral examination on page four.

A soft lead pencil should be used to fill in the ovals in the marking section, as well as the contact information at the beginning of the test.

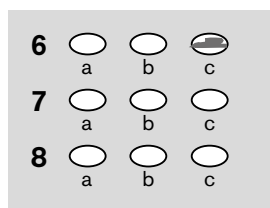

## Where are the tests evaluated? How are they evaluated?

The test results are scored electronically at telc headquarters in Frankfurt am Main, Germany. Each Answer Sheet S30 is scanned and compared to the answer keys, which are stored in a database. Based on this data, each candidate is issued a result sheet listing their personal test results and a telc certificate. Additionally, the data which has been saved for the scoring purposes is used to check and improve upon the quality of the examinations.

## telc Raters and Examiners

All examiners who evaluate the candidates' oral performances possess a telc examiner licence. They have received this licence by successfully participating in a telc training course. The requirements for becoming an examiner are: experience in teaching English, knowledge of the CEFR levels and an understanding of the communicative approach. telc licences are not valid indefinitely, rather they must be renewed at regular intervals. The examiner is required to attend another training course in order to renew their licence. All raters who evaluate the candidates' written expression have solid experience with telc tests. They have been trained in the test format at telc headquarters, continue to attend scaling events to ensure that their rating standards remain consistent and, each rater must also possess a valid telc rater licence, which must be renewed at regular intervals.

## Written Examination

The written examination lasts about 2 ½ hours and consists of the subtests “Reading Comprehension”, “Language Elements”, “Listening Comprehension” and “Writing”. There is a 20 minute break between the subtests “Language Elements” and “Listening Comprehension”. Before starting the examination, the candidates should fill in the information section on the Answer Sheet S30. In order to prevent misunderstandings, the invigilator writes the name of the examination centre, the date and the six-digit test version number on the board. The invigilator also needs to inform the candidates that dictionaries, mobile phones or other electronic devices are not allowed (Instructions §§ 15 and 16).

After the candidates have filled in the Answer Sheet S30, the invigilator should hand out the test booklets. Once this has been completed, the candidates have 90 minutes for the subtests “Reading Comprehension” and “Language Elements”. The starting and ending times should be written on the board and should be

visible for all of the candidates. Before the invigilator allows the candidates to leave for the break, they should collect page one of the Answer Sheet S30.

After the break, the “Listening” subtest begins. At the end of the “Listening” subtest, the candidates should separate page two from the Answer Sheet S30 and hand it in to the invigilator. The candidates should then continue with the “Written Expression” subtest. After 30 minutes, the invigilator collects page three of the Answer Sheet S30. The written examination is then finished.

## Oral Examination

### How long does the oral examination take?

The examination is with one candidate only and takes approximately 15-20 minutes. If candidates do not bring an object or a poster with them, a preparation time of 20 minutes is arranged before the examinations starts. During the preparation time candidates study the Task Sheet M50. The time allowed for examining should be according to these minutes: Part 1 = 3-5 minutes (Social and General English); Part 2 = 5 minutes (Business and Technical Situations); Part 3 = 5-7 minutes (Presentation).

### Preparing for the examination

All candidates have the opportunity to prepare individually at home and bring an object or a poster with them to the examination centre. If not, Task Sheet M50 is provided and candidates have 20 minutes to prepare their presentation. The use of dictionaries is not permitted.

The candidates are allowed to take notes during preparation time, which they are allowed to use during the examination. Therefore, the examination centre should provide stamped paper in the preparation room. The candidates are not allowed to make marks on the task sheets.

### What do the examiners do?

The examiners make sure all time restrictions are adhered to. It is theoretically possible that both examiners intervene during the preparation. However, it is recommended that one examiner takes the role of the interlocutor and the other the role of the assessor. These roles should be continued throughout the exam conversation.

The examiners record their marks on the Score Sheet M10 during the examination. Each examiner evaluates the candidates' performances individually. Each test part is to be assessed using the four evaluation criteria for oral expression, which means that each examiner needs to make eight assessments per candidate. After the candidate has left the room, the examiners compare their assessments. This exchange helps the examiners to re-evaluate their observations and to reach a consensus. Then the results are entered onto page four of the Answer Sheet S30.

### Who can receive a certificate?

A maximum total of 125 points can be awarded for both parts of the examination (written and oral). There is a total of 100 points for the written examination and a total of 25 points (50:2=25) for the oral examination.

To pass the whole examination, you must get at least 60% of the maximum total number of points in both the written and in the oral examination. This corresponds to a total of 60 points for the written examination and 15 points for the oral examination.

If you pass both parts of the examination, then the number of points awarded for the written examination is added to the number of points awarded for the oral examination to get the total.

The grade is then awarded according to the following table.

75.0–87.25	Points	Pass
87.5–99.75	Points	Satisfactory
100.0–112.25	Points	Good
112.5–125.0	Points	Very Good

If you fail or do not take one of the two parts of the examination you can retake that part of the examination during the calendar year in which you take the examination the first time or the following calendar year and have the points added together to get your final grade. The entire examination can be retaken as many times as you wish, e.g. if you fail or in order to get a better grade. It is, however, always the result of the final re-take which is valid.



# M10-Eng(B2)T

## English (B2) Technical Score Sheet

Surname:
First Name:
Examination Centre:

**One copy for each examiner.**

**Please note:  
This score sheet is to be retained  
by the examination centre.**

**Test 1: Social and General English**

	<b>A</b>	<b>B</b>	<b>C</b>	<b>D</b>
<b>80</b>	<input type="radio"/>	<input type="radio"/>	<input type="radio"/>	<input type="radio"/>

---

**Test 2: Everyday Situations in a Working Environment**

	<b>A</b>	<b>B</b>	<b>C</b>	<b>D</b>
<b>81</b>	<input type="radio"/>	<input type="radio"/>	<input type="radio"/>	<input type="radio"/>
<b>82</b>	<input type="radio"/>	<input type="radio"/>	<input type="radio"/>	<input type="radio"/>
<b>83</b>	<input type="radio"/>	<input type="radio"/>	<input type="radio"/>	<input type="radio"/>
<b>84</b>	<input type="radio"/>	<input type="radio"/>	<input type="radio"/>	<input type="radio"/>
<b>85</b>	<input type="radio"/>	<input type="radio"/>	<input type="radio"/>	<input type="radio"/>

---

**Test 3: Technical Description**

	<b>A</b>	<b>B</b>	<b>C</b>	<b>D</b>
<b>T</b>	<input type="radio"/>	<input type="radio"/>	<input type="radio"/>	<input type="radio"/>

---

**Pronunciation and Intonation**

	<b>A</b>	<b>B</b>	<b>C</b>	<b>D</b>
<b>P</b>	<input type="radio"/>	<input type="radio"/>	<input type="radio"/>	<input type="radio"/>

**This section  
is to be used  
for marks finally  
agreed on**

**Test 1: Social and General English**

	<b>A</b>	<b>B</b>	<b>C</b>	<b>D</b>
<b>80</b>	<input type="radio"/>	<input type="radio"/>	<input type="radio"/>	<input type="radio"/>

---

**Test 2: Everyday Situations in a Working Environment**

	<b>A</b>	<b>B</b>	<b>C</b>	<b>D</b>
<b>81</b>	<input type="radio"/>	<input type="radio"/>	<input type="radio"/>	<input type="radio"/>
<b>82</b>	<input type="radio"/>	<input type="radio"/>	<input type="radio"/>	<input type="radio"/>
<b>83</b>	<input type="radio"/>	<input type="radio"/>	<input type="radio"/>	<input type="radio"/>
<b>84</b>	<input type="radio"/>	<input type="radio"/>	<input type="radio"/>	<input type="radio"/>
<b>85</b>	<input type="radio"/>	<input type="radio"/>	<input type="radio"/>	<input type="radio"/>

---

**Test 3: Technical Description**

	<b>A</b>	<b>B</b>	<b>C</b>	<b>D</b>
<b>T</b>	<input type="radio"/>	<input type="radio"/>	<input type="radio"/>	<input type="radio"/>

---

**Pronunciation and Intonation**

	<b>A</b>	<b>B</b>	<b>C</b>	<b>D</b>
<b>P</b>	<input type="radio"/>	<input type="radio"/>	<input type="radio"/>	<input type="radio"/>

Date:	Examiner:
-------	-----------

**telc GmbH, Bleichstraße 1, D-60313 Frankfurt am Main**

# Answer Key



## Reading Comprehension

Item 1	d
Item 2	b
Item 3	c
Item 4	b
Item 5	b
Item 6	c
Item 7	+
Item 8	-
Item 9	c
Item 10	b
Item 11	b
Item 12	b
Item 13	c
Item 14	a
Item 15	b
Item 16	b
Item 17	c
Item 18	a
Item 19	c
Item 20	a
Item 21	a
Item 22	a
Item 23	c



## Language Elements

Item 24	d
Item 25	d
Item 26	a
Item 27	d
Item 28	a
Item 29	a
Item 30	b
Item 31	b
Item 32	d
Item 33	b



## Listening Comprehension

Item 34	Valve plug
Item 35	No
Item 36	Yes
Item 37	Reinforced rubber
Item 38	No
Item 39	No
Item 40	Plugs
Item 41	Yes
Item 42	Counter weights
Item 43	Yes
Item 44	-
Item 45	-
Item 46	+
Item 47	+
Item 48	-
Item 49	+
Item 50	-
Item 51	-
Item 52	+
Item 53	-
Item 54	+
Item 55	+
Item 56	+
Item 57	-
Item 58	+
Item 59	b
Item 60	b
Item 61	b
Item 62	c
Item 63	c
Item 64	Muthswamy
Item 65	6.492
Item 66	8-10 days
Item 67	215 by 312
Item 68	£75 - £82
Item 69	065437560
Item 70	8 1/2
Item 71	23,500 kg
Item 72	£75.43
Item 73	FG 18654 A



# Transcripts of the Listening Comprehension Texts

## Specifications and operating procedures

Now, let's turn to diagram I. This diagram I shows an automatic valve used to control the water pressure downstream of it. As you probably know, such valves are used in industry and in town water supplies. In the diagram the pressure on the left is controlled. By opening and closing as needed, the valve keeps the downstream water pressure constant. It could be used to supply water at an even pressure to a street, so that the water pressure remains constant no matter how many houses in the street use the water.

Generally speaking, the valve operates like a water tap in a house. A cone-shaped metal part, called the valve plug, is pushed downwards into an angled metal hole, called the valve seat. When the two are in contact with each other no water can flow. Valve plug and valve seat can be seen in the centre of the diagram, there.

Now, if a tap downstream is opened the pressure downstream begins to fall. This lower pressure is present also in the chamber on the top of the valve – called the control chamber, because the chamber is connected to the main pipe downstream of the valve by a thin pipe, called the sensing tube. The domeshaped control chamber and the sensing tube are clearly seen in the diagram.

The control chamber is sealed across its greatest diameter by a thin disc of reinforced rubber, designed to have a very long operating life. The movement of the rubber seal is opposed by a spring – called the control spring – which fits over the plug shaft and is held compressed between the pipe section of the valve and the rubber seal.

A valve such as this one is not adjustable. To change the operating pressure a new rubber seal and control spring must be installed. However, it will operate for some years without maintenance.

Now let's turn to diagram II, which shows a similar valve to I, but adapted for a different purpose.

On the extreme right of this diagram you will see a water tank. This tank is filled through a pipe, drawn schematically with broken lines at the bottom of the diagram. Whether or not the tank is filled depends on the movements of a system of rods, levers and a level sensor which I'll explain in some detail now. The ball shaped element situated in the float chamber next to the water tank is called the float. As its name suggests, the float floats on the surface of the water. Now, let us suppose the water level in the water tank falls. As it falls, the water level in the float chamber also falls and, consequently, so does the float. As the float moves down it will transmit its downward movement through a system of levers all the way down to the valve, where the two conical shaped plugs open the valve. You can see the plugs towards the bottom of the diagram in the centre of the valve.

A section of the rod, seen in the centre of the drawing, is made adjustable. This part serves to lengthen or shorten the rod, which connects the upper with the lower lever. Lengthening or shortening the rod will affect the opening and closing point of the valve.

There are two counterweights, mounted on the left hand sides of each of the two levers which serve to adjust the valve. Moving them horizontally along the levers will again alter the opening and closing point of the valve.

The arrangement includes a non-return-valve located in the feed pipe at the bottom of the diagram. It's a safety device which, as you can see, will close if the water pressure in the feed pipe falls and it thus prevents the tank emptying if the water supply fails.

## Discussions and lectures

### *Danger – Risky Kinobis*

**Interviewer:** Tests done recently in the USA and here in Britain as well as reports from owners of Kinobi cars have shown that Kinobi BKs can roll over at speeds as low as 20 miles per hour. I am going to talk to Marion Fielding from the Car-Owners' Association about the tests done and the accidents that have happened as a result of this danger in Kinobi cars. Marion, why did you, the Car-Owners' Association, decide to do tests on these cars?

**Marion Fielding:** Well, last year we heard that the Car-Owners' Federation in the United States had found that the Kinobi Karo was liable to roll over when being put through their accident avoidance test. We had only had a few reports of accidents involving this type of car but we decided to find out more about these accidents by doing our own tests.

**I:** And what have your tests found?

**M.F.:** Our own tests were done on only two different Kinobi BKs rather than on all the different models. These tests support the US results. These cars are liable to roll over, instead of sliding like most other cars, when going round a corner sharply. We think that this is unacceptable to Kinobi drivers, their passengers, and other road users in general.

**I:** How were the tests done?

**M.F.:** We put the Kinobis at 20 miles per hour through a test which includes a very tight bend. Our driver had to stop this test in the middle because he was sure the car would roll over.

**I:** Have you done this test on many other types of car?

**M.F.:** Oh, yes. We've been doing this test on cars for 25 years – normally at twice the speed – and have never before found a car so liable to roll over.

**I:** Does Kinobi know about this danger?

**M.F.:** The company knows that the cars are far less stable than other cars. Their handbook even advises drivers to avoid sharp turns. It says that failure to operate the car correctly may result in loss of control or the car rolling over. But we feel that even a very careful driver might find himself in situations where he cannot avoid a sharp turn. No car should roll over if going at a low speed.

**I:** Have there been many accidents because of this?

**M.F.:** We've now heard of 24 cases of Kinobis rolling over at quite low speeds. These have resulted in 2 deaths and 23 people hurt. There have been 95 accidents of this kind reported in the US.

**I:** Is anything being done about it?

**M.F.:** We have told the Ministry of Transport about what we have found as well as Kinobi. We've asked Kinobi to stop selling these cars and to warn all owners. But nothing has happened. We feel very strongly that something must be done before more people are killed or hurt. A number of accidents have happened although drivers were doing

nothing dangerous at all and were not even driving fast. Since doing the tests, we have heard of accidents in other parts of the world as well as accidents which happened when using reverse gear, braking suddenly and driving in and out of narrow entrances. We do not have details of these accidents but we would warn Kinobi owners to think very carefully about using their cars and especially about letting other drivers use them. Also we would like to hear from anyone who has had an accident with one of these cars or any other Kinobi model.

I: Thank you very much, Marion, for this information.

#### *Cooling down process heat.*

Heat, or waste heat, is an almost natural by-product of many industrial processes. This is particularly true for the generation of electrical power in thermal power stations. Thermal power stations are those that generate electricity by means of burning fossil fuels, but also in nuclear power stations. In such power stations the laws of physics limit the reduction of waste heat beyond a certain point. If this heat cannot be put to any sensible use it must be cooled down. Several approaches to cooling down this process heat exist, and I will explain two of them now.

Figure A shows the once-through cooling system. A once-through cooling system uses water drawn either from a lake or a river to supply cooling water to the heat exchanger. The heated water is then returned to the body of water. As a result of all the heat being discharged into rivers or lakes with such a system, the term "thermal pollution" has assumed significance. Laws now severely restrict the use of once-through cooling so that often it's not even available as an option.

In such cases closed-cycle cooling systems present an alternative. The next figure, Figure B, shows a closed-cycle cooling system. Here the cooling water is continuously recirculated through the power plant by means of large pumps. A cooling tower is used to remove the heat added to the circulating water. Now, water drawn from a natural source, again this could either be a lake or a river, would be used only to make up for losses. This isn't very much and the job is done by a small pump seen here as pump Y. Figure B shows a mechanical-draft cooling tower in which a large diameter fan driven by an electric motor forces air through the circulating water. There are also natural-draft design towers which do not need electricity to drive the fans. They are thus more energy efficient but the towers are much taller and they are therefore often not wanted for environmental reasons.

### Instructions and descriptions

#### **59. New Developments in the Car Industry**

Battery powered cars provide clean and noiseless alternatives to fuel powered vehicles for travel in cities. Asea Brown Boveri developed an efficient drive system featuring modern power electronics and a high-energy rechargeable sodium-sulphur battery as the prime mover. The energy-to-weight ratio of this battery is four times that obtained by lead batteries. The new battery, which operates at 300 degrees Celsius has no secondary reactions or gaseous emissions and its electrical efficiency is very high. Other electric vehicles require a dense network of charging stations. ABB has overcome this problem by developing an onboard battery charger mounted next to the motor which only needs to be connected to a household power socket. The new drive system will enable a typical car to be driven at 120 kilometres per hour over a range of 200 kilometres in town traffic.

#### **60. Shop-floor Safety Instruction**

When working with this lathe you must remember to clean it after each work period. Clean it with a medium width paint brush to remove all the metal chips. Never, I repeat, never use your hands as these metal chips can be very sharp. Also, don't use compressed air as flying particles might injure you or a nearby person. Finish by wiping down the machine with a soft cloth.

Keep the floor around the machine clear of chips and cutting fluid and keep oily cloths in a metal container that can be closed tightly, as they present a fire hazard. Most importantly, however, always wear appropriate clothing and goggles and avoid wearing greasy clothes - they catch fire easily. Now, let's come to the operation of the lathe ....

#### **61. Solar heating.**

The simplest solar energy systems are those designed for domestic space and hot water heating. In such systems, an inclined, southerly facing collector is typically coupled with a heat storage tank. The hot water collected in this tank heats up water for the hot water supply or for hot water heating. Diagram A shows a combination system that provides domestic hot water at 65 degrees Celsius and hot water for space heating at somewhat lower temperatures. Two pumps are needed, one to circulate water through the collector, and a second one to provide hot water for space heating. Neither of them run constantly but only when the sun shines - for the collector pump - and when hot water for space heating is needed for the other one.

Figure B shows a one-axis concentrator. It can be used if a simple flat-plate fixed collector does not provide high enough output temperatures, for example to produce steam for industrial purposes. The one-axis concentrator can be used for high efficiency and high temperatures at fairly low costs. The design shown in Figure B has a programmable drive to automatically follow the path of the sun.

#### **62. High Tension Cables for Car Ignition Systems**

In the past high tension cables for car ignition systems were constructed from a low resistance copper core enclosed in a rubber covering which gave the cable the necessary insulation. The rubber was then covered with a cotton band and the whole cable was coated with a kind of paint to protect it from wear and corrosion. In the new high tension cables the copper core has remained unchanged but the cotton and paint layers have been replaced with inorganic material. This is more efficient in protecting the rubber from heat, cold, oil, wear and corrosion.

#### **63. Comparing energy costs.**

Diagram I will serve to illustrate our brief comparison between hydrogen, natural gas and electricity as sources of energy. The columns show clearly that the end price for natural gas is much lower than the price for hydrogen gas and electricity. Not only are the production costs of natural gas lower but also the costs for transmission and distribution. The column for hydrogen energy shows interesting characteristics. While the production cost is higher than the one for electric power, the final selling price is lower due to relatively low transmission and distribution costs. It is however still more expensive than the price of natural gas energy. But this may change in the future, as obviously, there are only limited resources of natural gas so that in the future hydrogen energy may become a very competitive form of energy.

**Taking Notes**

- 64.** What is your name, please?  
My name is Muthswamy. That's M-U-T-H-S-W-A-M-Y
- 65.** How many employees do you have exactly?  
We now have 6492 employees.
- 66.** When can you deliver the goods?  
They will be sent to you in 8 to 10 days.
- 67.** What size is the paper?  
The paper is slightly larger than A4. It measures 215 millimetres by 312 millimetres.
- 68.** What is the initial cost of each lens?  
Each lens will initially cost 75 to 82 Pounds Sterling.
- 69.** Can you give me your fax number?  
My number is 06543 7650
- 70.** What size are they?  
We use American sizes, so that's eight and a half.
- 71.** What is the weight of the consignment?  
The consignment will have a total weight of 23,500 kilograms.
- 72.** How much is the VAT on that order?  
The VAT amounts to 75.43 Pounds Sterling.
- 73.** Can you tell me the invoice number?  
The number is FG 18654A







## ENGLISH

- C2** telc English C2

---

- C1** telc English C1

---

- B2-C1** telc English B2-C1 Business  
telc English B2-C1 University

---

- B2** telc English B2  
telc English B2 School  
telc English B2 Business  
telc English B2 Technical

---

- B1-B2** telc English B1-B2  
telc English B1-B2 School  
telc English B1-B2 Business

---

- B1** telc English B1  
telc English B1 School  
telc English B1 Business  
telc English B1 Hotel and Restaurant

---

- A2-B1** telc English A2-B1  
telc English A2-B1 School  
telc English A2-B1 Business

---

- A2** telc English A2  
telc English A2 School

---

- A1** telc English A1  
telc English A1 Junior

## DEUTSCH

- C2** telc Deutsch C2

---

- C1** telc Deutsch C1  
telc Deutsch C1 Beruf  
telc Deutsch C1 Hochschule

---

- B2-C1** telc Deutsch B2-C1 Medizin

---

- B2** telc Deutsch B2 Medizin  
Zugangsprüfung  
telc Deutsch B2+ Beruf  
telc Deutsch B2

---

- B1-B2** telc Deutsch B1-B2 Pflege

---

- B1** telc Deutsch B1+ Beruf  
Zertifikat Deutsch  
Zertifikat Deutsch für Jugendliche

---

- A2-B1** Deutsch-Test für Zuwanderer

---

- A2** telc Deutsch A2+ Beruf  
Start Deutsch 2  
telc Deutsch A2 Schule

---

- A1** Start Deutsch 1  
telc Deutsch A1 für Zuwanderer  
telc Deutsch A1 Junior

## ESPAÑOL

- B2** telc Español B2  
telc Español B2 Escuela

---

- B1** telc Español B1  
telc Español B1 Escuela

---

- A2-B1** telc Español A2-B1 Escuela

---

- A2** telc Español A2  
telc Español A2 Escuela

---

- A1** telc Español A1  
telc Español A1 Escuela  
telc Español A1 Júnior

## FRANÇAIS

- B2** telc Français B2

---

- B1** telc Français B1  
telc Français B1 Ecole  
telc Français B1 pour la Profession

---

- A2** telc Français A2  
telc Français A2 Ecole

---

- A1** telc Français A1  
telc Français A1 Junior

## ITALIANO

- B2** telc Italiano B2

---

- B1** telc Italiano B1

---

- A2** telc Italiano A2

---

- A1** telc Italiano A1

## TÜRKÇE

- C1** telc Türkçe C1

---

- B2** telc Türkçe B2  
telc Türkçe B2 Okul

---

- B1** telc Türkçe B1  
telc Türkçe B1 Okul

---

- A2** telc Türkçe A2  
telc Türkçe A2 Okul  
telc Türkçe A2 İlkokul

---

- A1** telc Türkçe A1

## РУССКИЙ ЯЗЫК

- B2** telc Русский язык B2

---

- B1** telc Русский язык B1

---

- A2** telc Русский язык A2

---

- A1** telc Русский язык A1

## PORTUGUÊS

- B1** telc Português B1

## اللغة العربية

- B1** telc اللغة العربية B1

## JĘZYK POLSKI

- B1-B2** telc Język polski B1-B2 Szkoła

**Examination Preparation**

# MOCK EXAMINATION 1

## ENGLISH B2 TECHNICAL

The two main characteristic features of telc examinations are test papers based on language tasks formulated in a clear and understandable way and standardised marking criteria applied in an objective way. The comprehensively defined test specifications and uniform marking criteria ensure that these features apply to all examinations and are identical for all languages covered by the telc programme. This equally applies to the test format. The mock examination presented here enables teachers and learners to simulate the precise conditions under which the examinations take place, both from the perspective of organising the test as well as from the point of view of the test materials. In this way, it is possible to fully prepare candidates for the examination. The mock examination can also be used for practice purposes, for examiner training and for general information.